

in[mm]

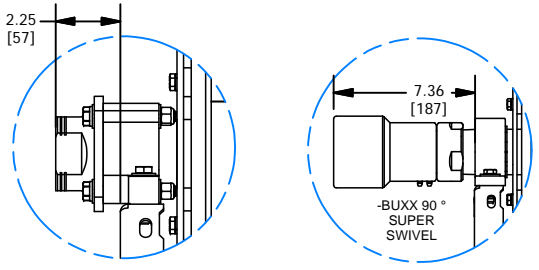
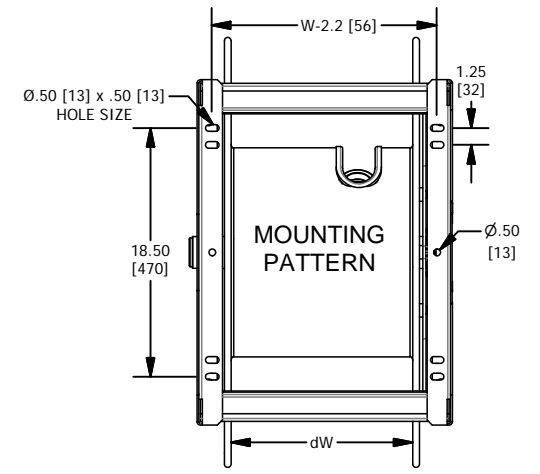
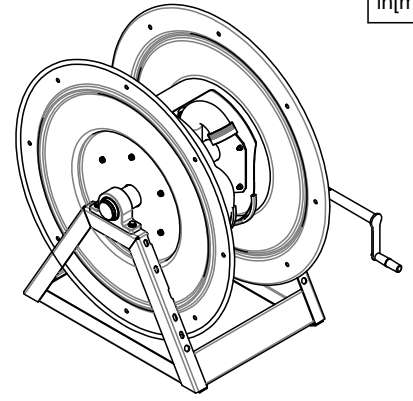
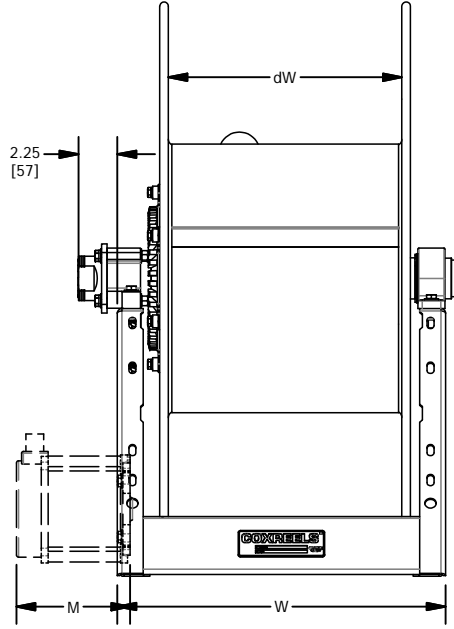
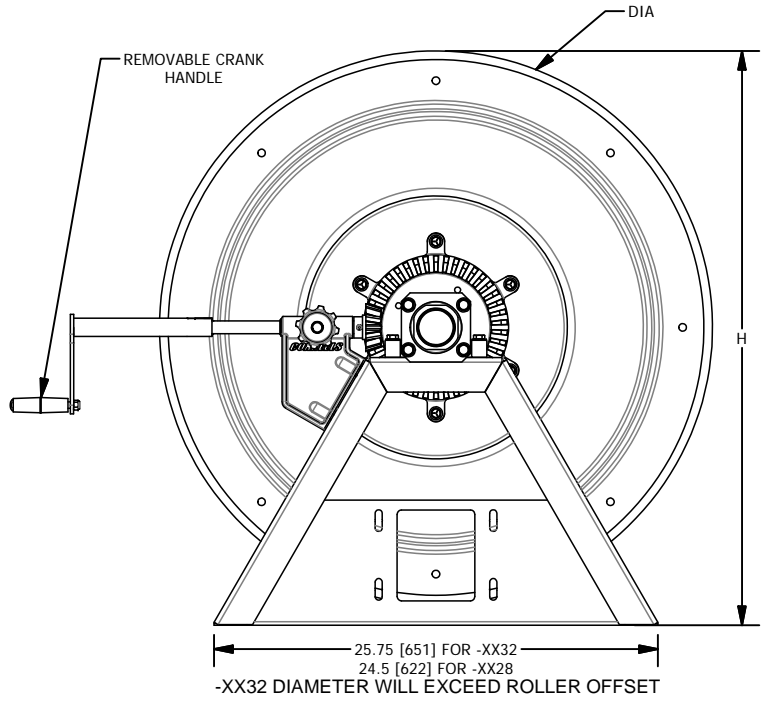

SPECIFICATIONS		
FEATURE	SPEC.	OPTION
PRESSURE	1000 PSI [69 BAR]	1500 PSI [103 BAR] W/ -BUXX SWIVEL
TEMPERATURE (HOSE DEPENDANT)	-40 F TO 225 F [-40 C TO 107 C]	-60 F TO 400F [-51 C TO 204 C]
INLET THREAD	2" NPT FEMALE	1.5" NPT FEMALE
OUTLET THREAD	2" NPT FEMALE	1.5" NPT FEMALE
HOLE SIZES	.5" [13]	-

***ALL DIMS ROUNDED TO QUARTER INCH [.5MM]

MOTOR DRIVE SYSTEM	DIMENSION "M" in[mm]	ADD TO WEIGHT lb [kg]
ELECTRIC MOTOR: 1/2HP (12V & 24VD C, 115V & 230V AC)	6.59 [167]	26 [12]
AIR MOTOR (6 VANE, IRON)	5.42 [138]	8 [4]
HYDRAULIC	3.77 [96]	6 [3]

MODEL	DIA in[mm]	dW in[mm]	W in[mm]	H in[mm]	CAPACITY		WEIGHT lb[kg]
					1.5" (2-1/16" OD) ft[m]	2" (2-9/16" OD) ft[m]	
1195-932	32 [813]	9.5 [241]	15 [381]	33.25 [845]	60 [18.2]	50 [15]	128 [58]
1195-1728	28 [711]	17.5 [444]	23 [584]	30.25 [762]	85 [27]	60 [18.2]	134 [61]
1195-1332	32 [813]	13.5 [343]	19 [483]	33.25 [845]	100 [30]	75 [23]	148 [67]
1195-2428	28 [711]	24 [610]	29.5 [750]	30.25 [762]	135 [41]	90 [29]	169 [77]
1195-2032	32 [813]	20 [508]	25.5 [648]	33.25 [845]	150 [46]	115 [35]	186 [84]
1195-3228	28 [711]	32 [813]	37.5 [952]	30.25 [762]	175 [53]	125 [38]	218 [99]

PART NUMBER

DISK Ø COLOR ROLLERS & SETUP

1195 - XX XX - XX - XXXX

DRUM WIDTH MOTOR, CRANK & BRAKE OPTIONS PLUMBING & SWIVEL OPTIONS

MATERIAL SPECIFICATIONS		
COMPONENT	MATERIAL	OPTIONS
PLUMBING	STEEL	302/304 STAINLESS STEEL
SWIVEL	INLINE NI PLATED STEEL	302 INLINE & 440 SS 90 DEGREE SS OR NI
SEALS	NITRILE	VITON, EPDM, AFLAS (SS OR NI 90 DEGREE ONLY)
REEL	STEEL	-
BEARINGS	BRONZE, SELF LUBE	-
CHAIN GUARD	STEEL	-
FINISH	BLUE POLYESTER POWDER COAT	RED(R), GREEN(N), WHITE(W), BLACK(WRINKLE(C)/ GLOSS(K)) GREY(G)

UNLISTED OPTIONS & CUSTOM REELS

NOT ALL OPTIONS ARE LISTED, CONTACT YOUR SALES REPRESENTATIVE OR FACTORY FOR ADDITIONAL OPTIONS & CUSTOM MODIFICATIONS

COXREELS

5865 S Ash Avenue Tempe, Az 85283
1-800-COX-REEL www.coxreels.com

THIS DOCUMENT CONTAINS PROPRIETARY INFORMATION AND IS THE PROPERTY OF COXREELS, INC. THE COPYING, DISTRIBUTION AND UTILIZATION OF THIS DOCUMENT AS WELL AS COMMUNICATION OF ITS CONTENT TO OTHERS WITHOUT THE WRITTEN AUTHORIZATION OF COXREELS, INC., IS PROHIBITED.

TITLE: **1195 SERIES**

DWG. NO.: **1195 SERIES** REV. -

3RD ANGLE INTERPERT PER ASME : Y14.5M-1994 DO NOT SCALE DWG. SIZE: A SHT:1 OF:2

ROLLER BRACKET OPTIONS

in[mm]

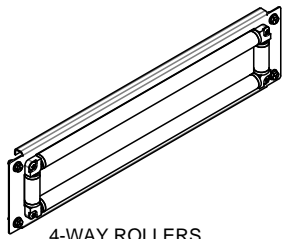

4-WAY ROLLERS
STAINLESS STEEL
Ø1" ROLLERS

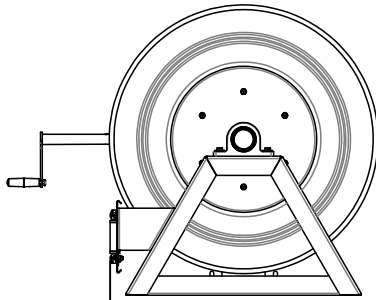

1.75
[44]

BOTTOM -XX28
4-WAY ROLLERS
SIDE VIEW

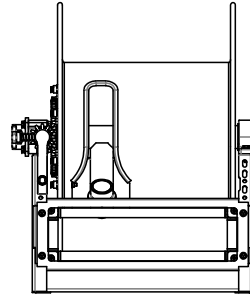

BOTTOM -XX28
4-WAY ROLLERS
FRONT VIEW

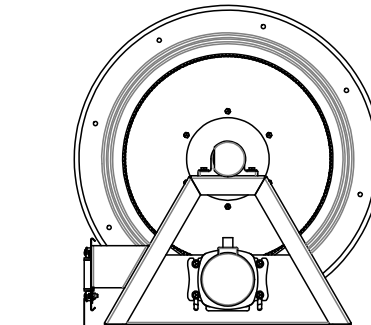

2.00
[51]

BOTTOM -XX32
4-WAY ROLLERS
SIDE VIEW

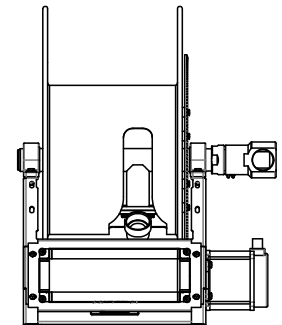

BOTTOM -XX32
4-WAY ROLLERS
FRONT VIEW

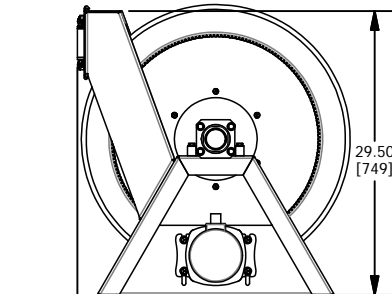

2.25
[57]

TOP -XX28
4-WAY ROLLERS
SIDE VIEW

29.50
[749]

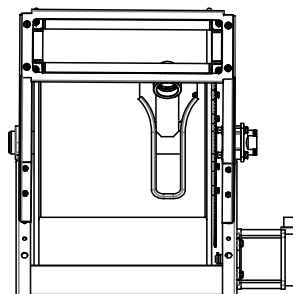

TOP -XX28
4-WAY ROLLERS
FRONT VIEW

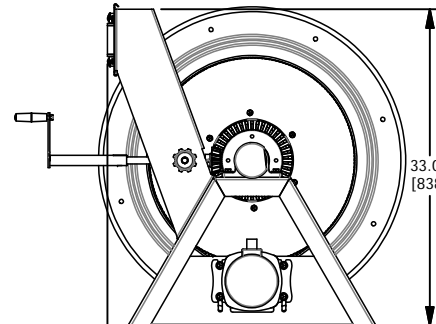

2.25
[57]

TOP -XX32
4-WAY ROLLERS
SIDE VIEW

33.00
[838]

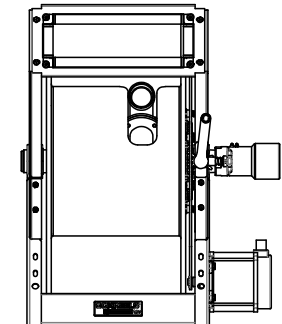

TOP -XX32
4-WAY ROLLERS
FRONT VIEW

GUARDING OPTIONS
STEEL GEAR GUARD

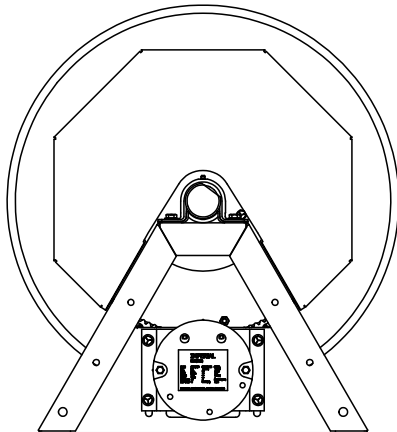
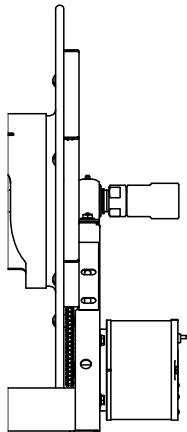

BEVEL CRANK
BEVEL CRANK WITH
REMOVABLE HANDLE

FRICION BRAKE

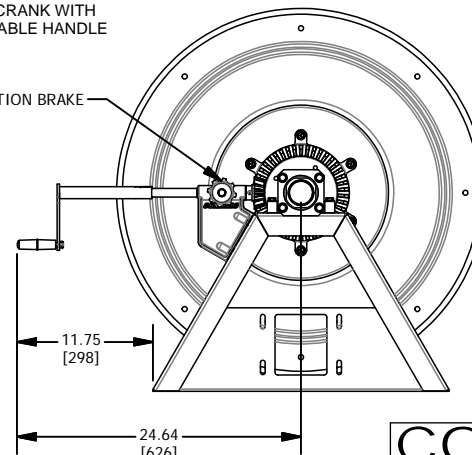

11.75
[298]

24.64
[626]

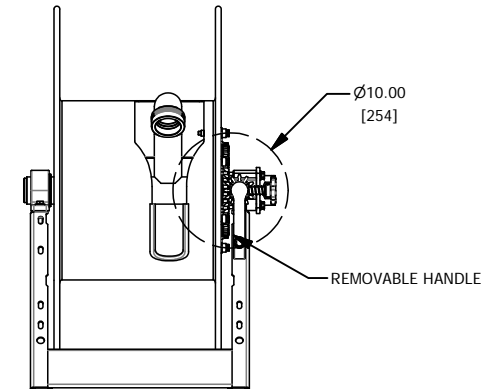

Ø10.00
[254]

REMOVABLE HANDLE

COXREELS
5865 S Ash Avenue Tempe, Az 85283
1-800-COX-REEL www.coxreels.com
THIS DOCUMENT CONTAINS PROPRIETARY
INFORMATION AND IS THE PROPERTY OF COXREELS,
INC. THE COPYING, DISTRIBUTION AND UTILIZATION
OF THIS DOCUMENT AS WELL AS COMMUNICATION
OF ITS CONTENT TO OTHERS WITHOUT THE WRITTEN
AUTHORIZATION OF COXREELS, INC., IS PROHIBITED.

TITLE:		1195 SERIES
DWG. NO.:	1195 SERIES	REV. -
3RD ANGLE	INTERPERT PER ASME : Y14.5M-1994 DO NOT SCALE DWG.	SIZE: A SHT:2 OF: 2